

Clamp-Tite Spun Copper Drain No Hub

Part #	Size	Weight
300-3180	2"	5.10 lbs
300-3185	3"	5.15 lbs
300-3190	4"	5.30 lbs

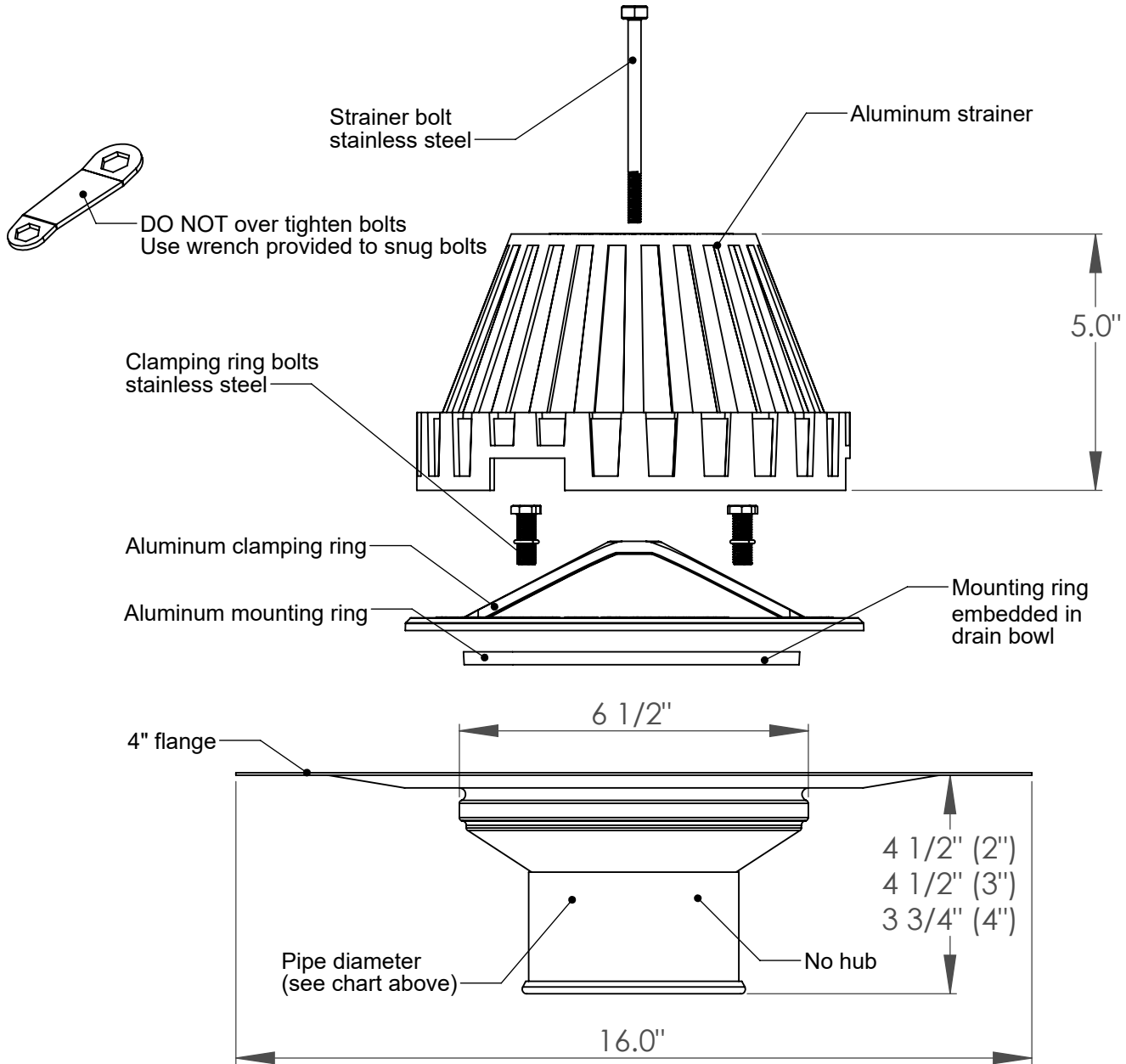

Features

- Meets CSA B79 and ASME A112.6.4 Standards
- Lower clamping ring mount is embedded into drain bowl
- All fasteners are stainless steel
- No vertical studs to interfere with membrane
- Hub outlet for full size mechanical connection
- Available in sizes 2", 3" and 4"
- Also available in TPO Direct Weld

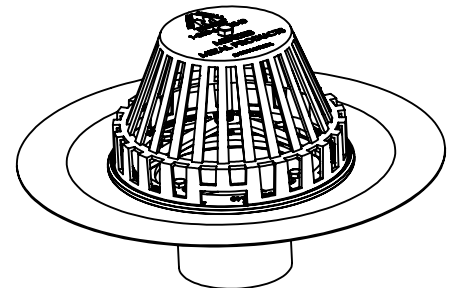

Innovative Ideas Since 1978

PROPRIETARY AND CONFIDENTIAL

DATE: 05/25/16

Part title & J#

THE INFORMATION CONTAINED IN THIS DRAWING IS THE SOLE PROPERTY OF MENZIES METAL PRODUCTS. ANY REPRODUCTION IN PART OR AS A WHOLE WITHOUT THE WRITTEN PERMISSION OF MENZIES METAL PRODUCTS IS PROHIBITED.

DRAWN BY: ZV

COMMENTS:

DO NOT SCALE DRAWING

SIZE

A



Clamp-Tite Spun Copper Drain No Hub

19370 - 60th Ave., Surrey, BC V3S 3M2

Ph: 604-530-0712

Fax: 604-530-8482

www.menzies-metal.com