

# Econo Aluminum Drain

Part #	Description	Pcs/Ctn	Weight
300-3320	2" Hotweld	25	0.87 lbs/pc
300-3325	3" Hotweld	12	1.73 lbs/pc
300-3330	4" Hotweld	8	2.89lbs/pc

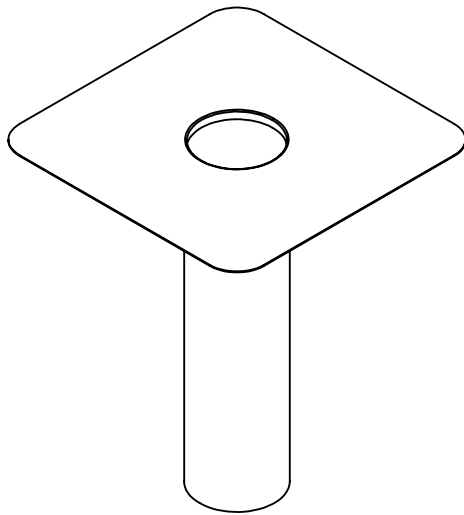

Aluminum flange  
 2" drain 7" x 7"  
 3" drain 9" x 9"  
 4" drain 12" x 12"

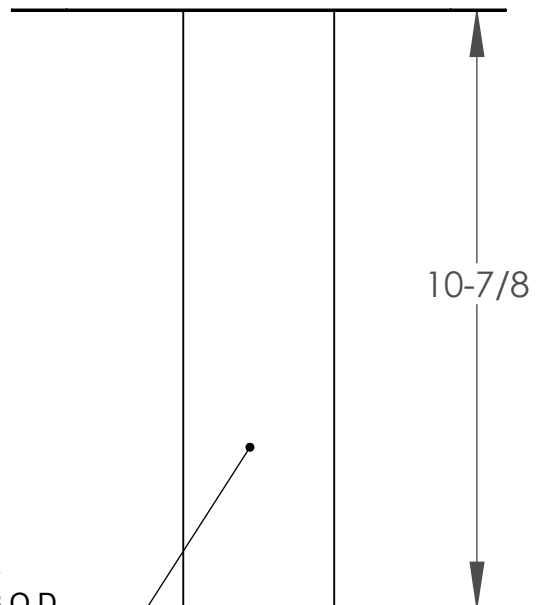
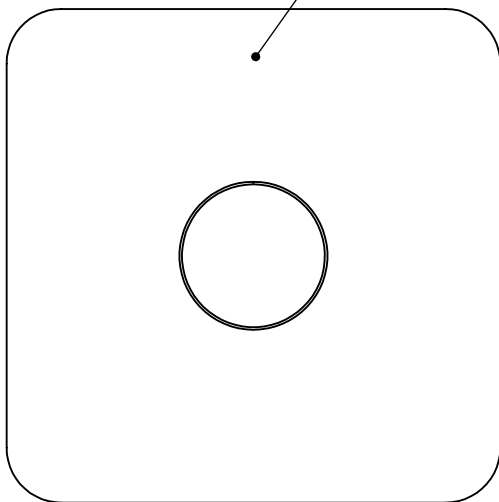

Pipe diameter  
 2" drain 1-7/8 O.D.  
 3" drain 2-3/4 O.D.  
 4" drain 3-3/4 O.D.

## For use on overhang over non-heated areas

- Other sizes and extended pipe lengths (Special order)
- Available in TPO Direct Weld
- Longer pipes available

Innovative Ideas Since 1978

**PROPRIETARY AND CONFIDENTIAL**

THE INFORMATION CONTAINED IN THIS DRAWING IS THE SOLE PROPERTY OF MENZIES METAL PRODUCTS. ANY REPRODUCTION IN PART OR AS A WHOLE WITHOUT THE WRITTEN PERMISSION OF MENZIES METAL PRODUCTS IS PROHIBITED.

DATE: 06/27/17

DRAWN BY: ZV

COMMENTS:

DO NOT SCALE DRAWING

Part title & J#

SIZE

**A**



## Econo Aluminum Drain

19370 - 60th Ave., Surrey, BC V3S 3M2  
 Ph: 604-530-0712  
 Fax: 604-530-8482  
[www.menzies-metal.com](http://www.menzies-metal.com)