

# Clamp-Tite Spun Aluminum Drain TPO

Part #	Size	Weight
300-3390TPO	2" (1-7/8 O.D.)	3.70 lbs
300-3395TPO	3" (2-3/4" O.D.)	3.70 lbs
300-3400TPO	4" (3-3/4" O.D.)	4.00 lbs
300-3401TPO	5" (4-3/4" O.D.)	5.00 lbs
300-3402TPO	6" (5-3/4" O.D.)	6.00 lbs

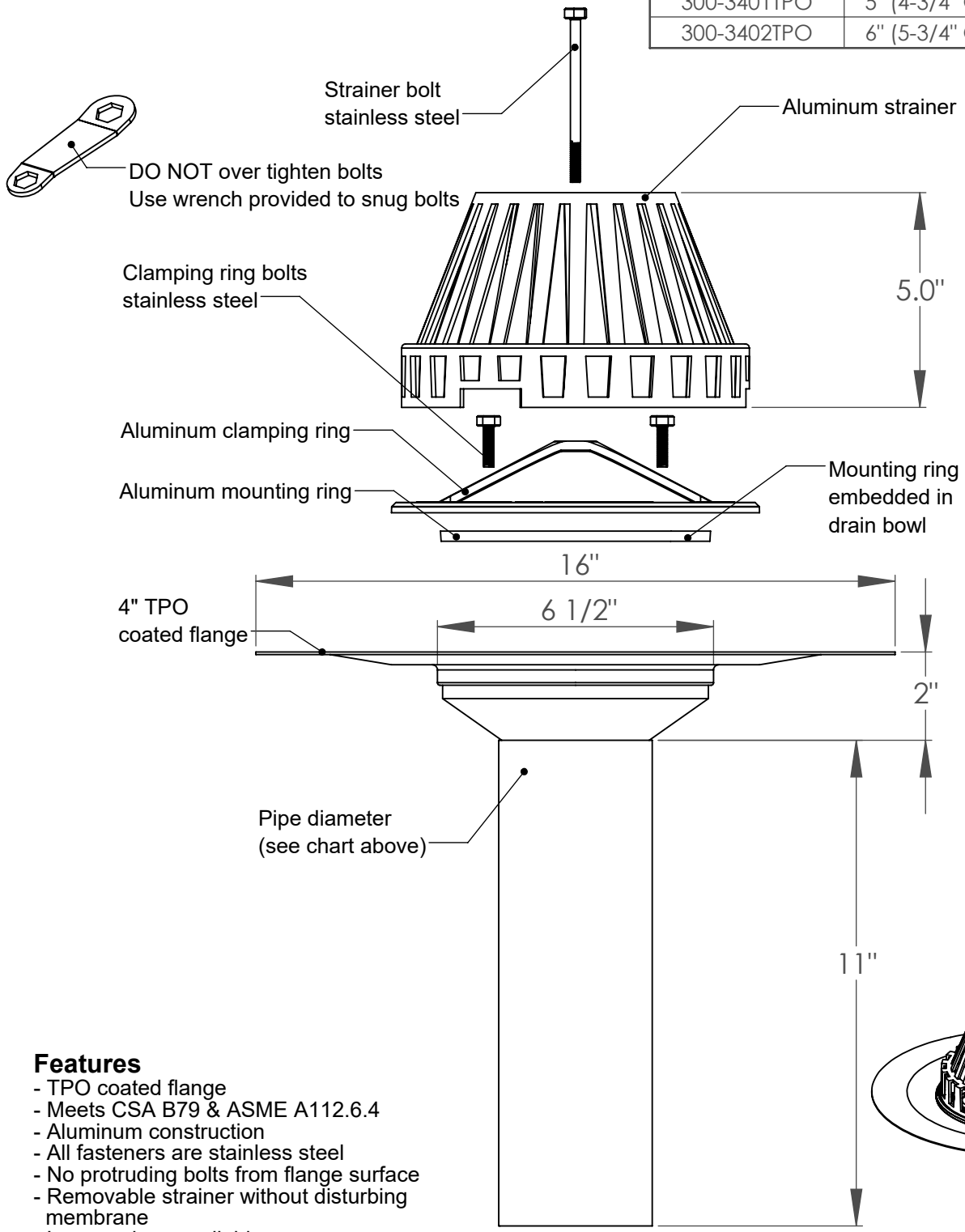

## Features

- TPO coated flange
- Meets CSA B79 & ASME A112.6.4
- Aluminum construction
- All fasteners are stainless steel
- No protruding bolts from flange surface
- Removable strainer without disturbing membrane
- Longer pipes available

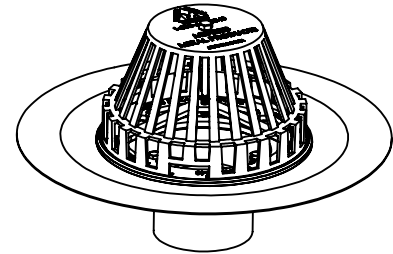

Innovative Ideas Since 1978

PROPRIETARY AND CONFIDENTIAL

THE INFORMATION CONTAINED IN THIS DRAWING IS THE SOLE PROPERTY OF MENZIES METAL PRODUCTS. ANY REPRODUCTION IN PART OR AS A WHOLE WITHOUT THE WRITTEN PERMISSION OF MENZIES METAL PRODUCTS IS PROHIBITED.

DATE: 05/21/16

DRAWN BY: ZV

COMMENTS:

DO NOT SCALE DRAWING

Part title & J#

**Clamp-Tite Spun Aluminum Drain TPO**

SIZE

**A**



19370 - 60th Ave., Surrey, BC V3S 3M2  
 Ph: 604-530-0712  
 Fax: 604-530-8482  
[www.menzies-metal.com](http://www.menzies-metal.com)