

# Econo Aluminum Drain TPO

Part #	Description	Weight
300-3320TPO	2" (1 7/8" OD)	0.87 lbs/pc
300-3325TPO	3" (2 3/4" OD)	1.73 lbs/pc
300-3330TPO	4" (3 3/4" OD)	2.89lbs/pc

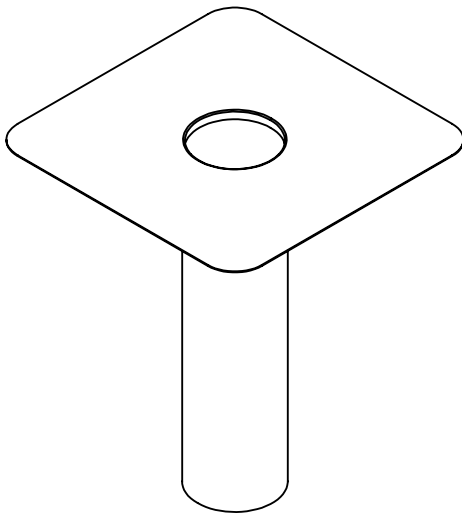

TPO coated aluminum flange  
 2" drain 7" x 7"  
 3" drain 9" x 9"  
 4" drain 12" x 12"

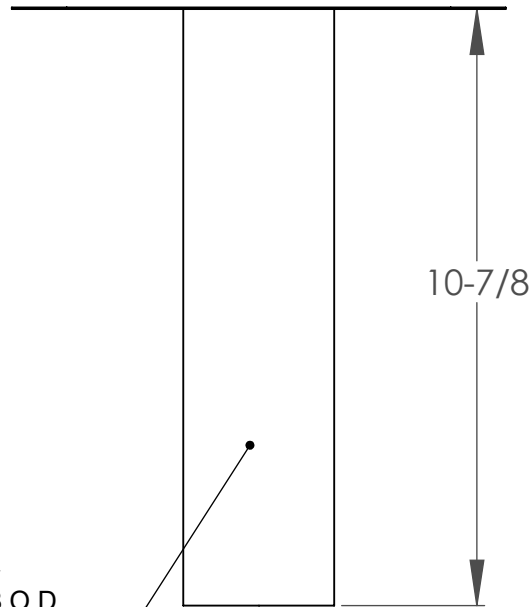
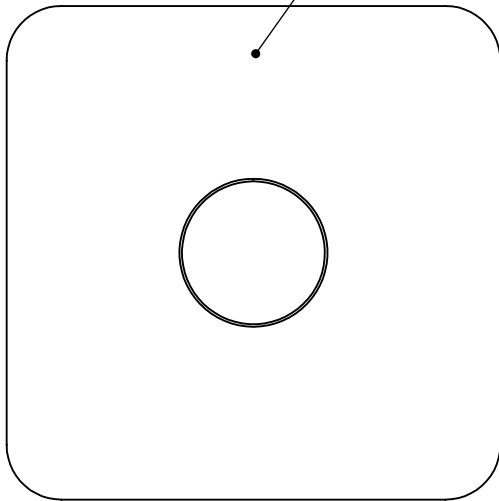

Pipe diameter  
 2" drain 1-7/8 O.D.  
 3" drain 2-3/4 O.D.  
 4" drain 3-3/4 O.D.

## For use on overhang over non-heated areas

- TPO coated flange
- Other sizes and extended pipe lengths (Special order)
- Longer pipes available

Innovative Ideas Since 1978

**PROPRIETARY AND CONFIDENTIAL**

THE INFORMATION CONTAINED IN THIS DRAWING IS THE SOLE PROPERTY OF MENZIES METAL PRODUCTS. ANY REPRODUCTION IN PART OR AS A WHOLE WITHOUT THE WRITTEN PERMISSION OF MENZIES METAL PRODUCTS IS PROHIBITED.

DATE: 07/01/17

DRAWN BY: ZV

COMMENTS:

DO NOT SCALE DRAWING

Part title & J#

## Econo Aluminum Drain TPO

SIZE

**A**



19370 - 60th Ave., Surrey, BC V3S 3M2  
 Ph: 604-530-0712  
 Fax: 604-530-8482  
[www.menzies-metal.com](http://www.menzies-metal.com)